

**PERFORMANCE TEST REPORT**

**Rendered to:**

**GLASSCRAFT DOOR COMPANY**

**SERIES/MODEL: Mahogany Entry Door**

**PRODUCT TYPE: 6' x 8' Double Inswing Hardwood TDL Door  
with Half Circle TDL Transom**

<b>Title</b>	<b>Summary of Results</b>
Uniform Load Deflection Test Pressure	+44.24 psf / -55.72 psf
Uniform Load Structural Test Pressure	+61.94 psf / -83.58 psf

**This report contains in its entirety:**

**Cover Page: 1 page**  
**Report Body: 6 pages**  
**Drawings: 14 pages**

Reference should be made to Architectural Testing, Inc. Report No. 81839.01-801-44 for complete test specimen description and data.

**PERFORMANCE TEST REPORT**

Rendered to:

GLASSCRAFT DOOR COMPANY  
2002 Brittmoore Road  
Houston, Texas 77043-2209

Report No.: 81839.01-801-44  
Revision 2: 06/30/08  
Test Dates: 04/29/08  
Through: 05/14/08  
Report Date: 06/20/08  
Expiration Date: 05/14/12

**Project Summary:** Architectural Testing, Inc. was contracted by GlassCraft Door Company to perform testing on a Series/Model Mahogany Entry Door, 6' x 8' double inswing hardwood TDL door with half circle TDL transom. Test specimen description and results are reported herein.

**Test Method:** The test specimen was evaluated in accordance with:

*ASTM E 330-02, Test Method for Structural Performance of Exterior Windows, Curtain Walls and Doors by Uniform Static Air Pressure Difference*

**Test Specimen Description:**

**Series/Model:** Mahogany Entry Door

**Product Type:** 6' x 8' Double Inswing Hardwood TDL Door with Half Circle TDL Transom

**Overall Area:** 80.78 ft<sup>2</sup>

**Door Description**

**Overall Size:** 74-1/8" wide by 137-3/4" high

**Leaf Size (Active):** 36" wide by 96" high

**Leaf Size (Inactive):** 35-7/8" wide by 96" high plus astragal

**Glass Size:** 11" wide by 20" high

**Glazing Type:** Six sealed insulating glass units comprised of one piece of 1/8" thick tempered glass at the exterior and one piece of 1/8" thick tempered glass at the interior. The sheets were separated by a 1/2" aluminum spacer system providing a 3/4" overall thickness.

**Test Specimen Description:** (Continued)

**Door Description** (Continued)

**Glazing Details:** Interior glazed with double-sided butyl tape and a wood glazing bead secured by 1" x 0.040" x 0.050" rectangular shank 0.050" x 0.080" head brad nails (18 gauge brad nail) 1" from each corner and on 6" spacing thereafter.

**Weatherstripping:** One five finger vinyl sweep at the bottom of the door leaf. One row of custom shaped foam-filled vinyl weatherstrip at the head and jambs.

**Frame Construction:** The door frame was constructed of 4-5/8" by 1-1/4" hardwood head and jambs, a 3-1/4" by 1-3/8" hardwood T-astragal and included an adjustable extruded aluminum and composite threshold. The head and jambs were kerfed to accept the weatherstripping. The corners were coped and butted and secured with two #8 x 1-1/2" and five #8 x 3" screws at the threshold and with four #8 x 1-1/2" and two #8 x 3" screws at the head. The astragal was attached to the inactive panel with sixteen 2" x 0.040" x 0.050" rectangular shank 0.050" x 0.080" head brad nails located 1" from each end and on 8" spacing.

**Leaf Construction:** The door leaf was constructed of 1-3/4" thick hardwood and utilized a glued cove and bead joint, reinforced with 1/2" diameter by 4-1/2" long wood dowels. Two dowels were located at the top and middle rail to stile joint, and four dowels were located at the bottom rail to stile joint.

**Hardware:** One Schlage F-300 Series single-point lockset 36" on center from bottom of the leaf and a Schlage deadbolt located 41-5/8" on center from the bottom of the leaf. Two metal strike plates located in the astragal secured with two #8 x 2-1/2" flat head screws. Four 4" butt type hinges fastened to each leaf with four #8 x 3" screws. Each hinge was secured to the jamb with two #8 x 3" screws and two #8 x 1" flat head screws. The hinges were located at 9-1/8", 34-1/2", 59-1/2" and 84-3/4" on center from the top of the jamb. Surface bolts were attached to the top and bottom of each leaf with four #10 x 1" flat head machine screws with a 1-1/2" long blind nut. Strike plates for the surface bolts were attached to the head jamb with two #10 x 2" screws and to the threshold with two #10 x 3" sheet metal screws.

**Drainage:** Sloped sill.

**Installation:** The jambs were secured to a #2 Yellow Pine 2x12 test buck with two #8 x 3" screws at each hinge (16 total). The unit was secured through the jambs with #8 x 3" screws located 2" from the bottom of each jamb and on 12" centers thereafter.

**Test Specimen Description:** (Continued)

**Transom Description**

**Overall Size:** 74-1/8" wide by 37-5/8" high

**Panel Size:** 72-3/8" wide by 36" high

**Glass Size:** 67-3/4" wide by 31-3/8" high

**Glazing Type:** Twelve sealed insulating glass units comprised of one sheet of 1/8" thick tempered glass at the exterior and one sheet of 1/8" thick tempered glass at the interior. The sheets were separated by a 1/2" aluminum spacer system providing a 3/4" overall thickness.

**Glazing Details:** Interior glazed with double-sided butyl tape and a wood glazing bead fastened with 1" x 0.040" x 0.050" rectangular shank 0.050" x 0.080" head brad nails (18 gauge brad nail) 1" from each corner and on 6" spacing. The lites were arranged in a radial pattern.

**Weatherstripping:** No weatherstripping was utilized.

**Frame Construction:** The frame was constructed of 4-1/2" by 3/4" hardwood. The corners were secured with two #8 x 3" wood screws.

**Panel Construction:** The panel was constructed of 1-3/4" thick laminated hardwood and utilized a glued cove and bead joint. Two #8 x 3" screws were located at each stile to rail joint. The panel was secured to the transom frame with seven #8 x 3" screws located 3" from each corner and on 18" spacing around the arch, three #8 x 3" screws located 3" from each corner and in the center across the sill and with 1/2" quarter round trim fastened by 1-1/4" x 0.040" x 0.050" rectangular shank 0.050" x 0.080" head brad nails (18 gauge brad nail) 1" from each corner and on 6" spacing. The transom was attached to the head jamb of the door with six #8 x 1-1/2" screws, one 3" from each corner of the head/sill and on 13" spacing across the head/sill.

**Installation:** The jambs were secured to a #2 Yellow Pine test buck with seven #8 x 3" wood screws, one 3" from each corner and on 16" spacing around the arch.

**Test Results:** The temperature during testing was 79°F. The results are tabulated as follows:

<u>Test Method</u>	<u>Title of Test</u>	<u>Results</u>
ASTM E 330	Uniform Load Deflection (Deflections reported were taken on the astragal) (Loads were held for 10 seconds) 44.24 psf (positive) 55.72 psf (negative)	0.17" 0.19"
ASTM E 330	Uniform Load Deflection (Deflections reported were taken on the transom sill) (Loads were held for 10 seconds) 44.24 psf (positive) 55.72 psf (negative)	0.84" 1.07"
ASTM E 330	Uniform Load Structural (Permanent sets reported were taken on the astragal) (Loads were held for 10 seconds) 61.94 psf (positive) 83.58 psf (negative)	0.05" <0.01"
ASTM E 330	Uniform Load Structural (Permanent sets reported were taken on the transom sill) (Loads were held for 10 seconds) 61.94 psf (positive) 83.58 psf (negative)	<0.01" 0.02"

**General Note:** All testing was performed in accordance with the referenced standards.

Tape and film were used to seal against air leakage during structural testing. In our opinion, the tape and film did not influence the results of the test.

**Drawing Reference:** The test specimen drawings have been reviewed by Architectural Testing and are representative of the test specimen reported herein.

**List of Official Observers:**

<u>Name</u>	<u>Company</u>
Gene Denley Andy Cost	GlassCraft Door Company Architectural Testing, Inc.

Detailed drawings, data sheets, representative samples of test specimens, a copy of this report, or other pertinent project documentation will be retained by Architectural Testing, Inc. for a period of four years from the original test date. At the end of this retention period, such materials shall be discarded without notice and the service life of this report will expire.

Results obtained are tested values and were secured by using the designated test methods. No conclusions of any kind regarding the adequacy or inadequacy of the glass in the test specimen can be made. This report does not constitute certification of this product nor an opinion or endorsement by this laboratory. It is the exclusive property of the client so named herein and relates only to the specimen tested. This report may not be reproduced, except in full, without the written approval of Architectural Testing, Inc.

For ARCHITECTURAL TESTING, INC:

---

Andy Cost  
Laboratory Manager

---

John H. Waskow, P.E.  
Director of Regional Operations

---

Jeffrey T. Kaminski, P.E.  
Senior Project Engineer

AC:hd/cmd

Attachments (pages): This report is complete only when all attachments listed are included.  
Appendix-A: Drawings (14)

### Revision Log

<u>Rev. #</u>	<u>Date</u>	<u>Page(s)</u>	<u>Revision(s)</u>
0	06/20/08	N/A	Original report issue
1	06/26/08	Cover and Page 1	Corrected Series/Model to Mahogany
2	06/30/08	Cover and Page 1	Changed Series/Model from Mahogany to Mahogany Entry Door

## **Appendix A**

### **Drawings**



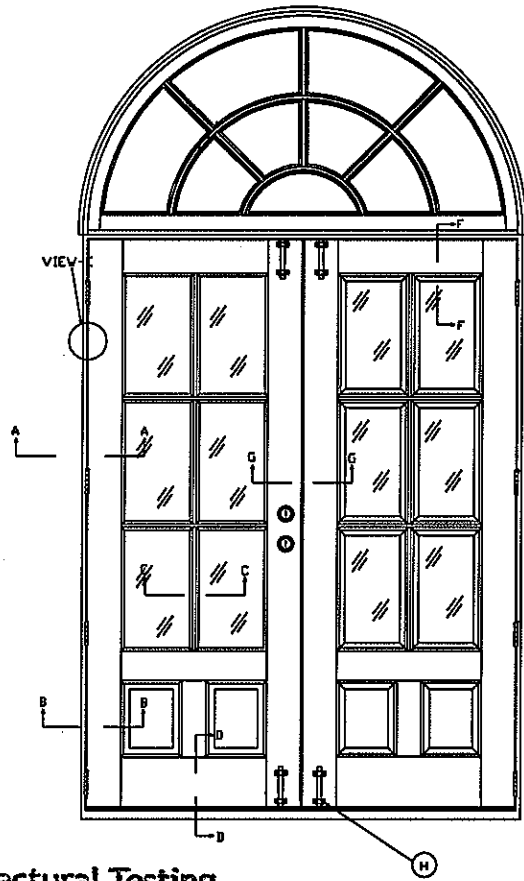

ELEVATION

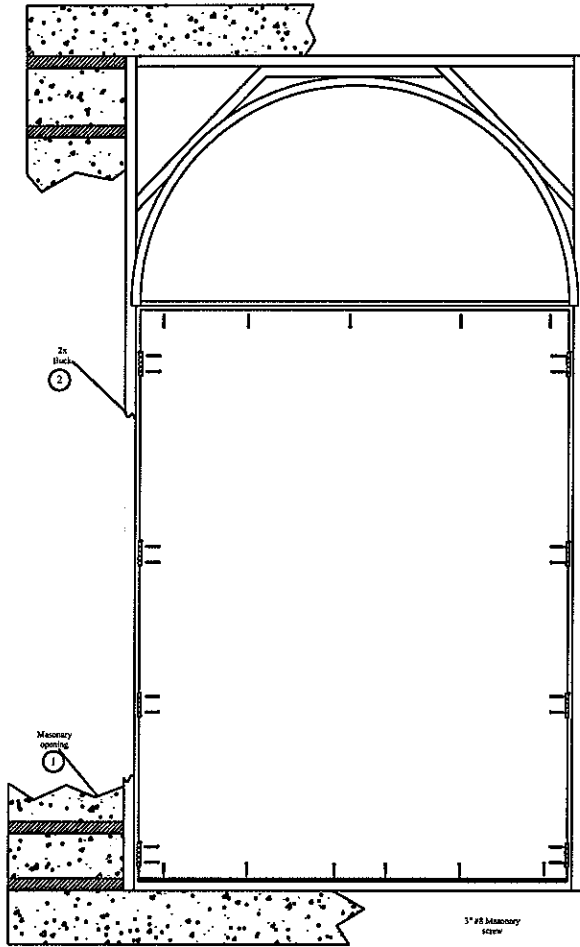

ANCHORING LAYOUT

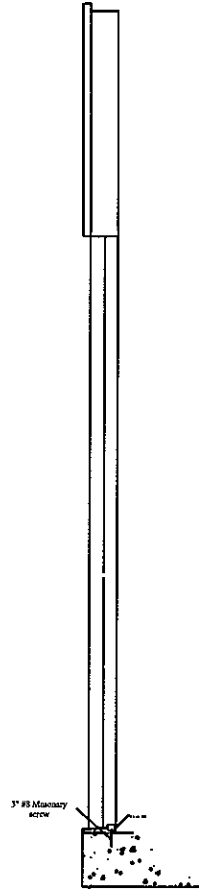

Set frame sill in concrete or bed of caulk

In Swing

Architectural Testing

Test sample complies with these details.  
Deviations are noted.

Report# 51839.01-801-44  
Date 6/10/08 Tech [Signature]

Inside View / In Swing

Glass\*Craft

Hardwood Double Glazed Doors/Transom

Test sample complies with these details.  
Deviations are noted.

Report# 81839-01-801-44  
Date 01/10/08 Tech E

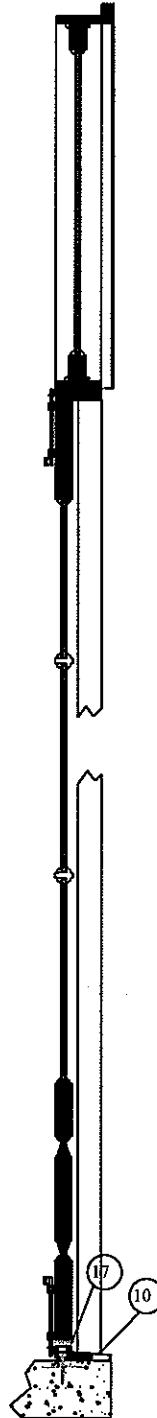
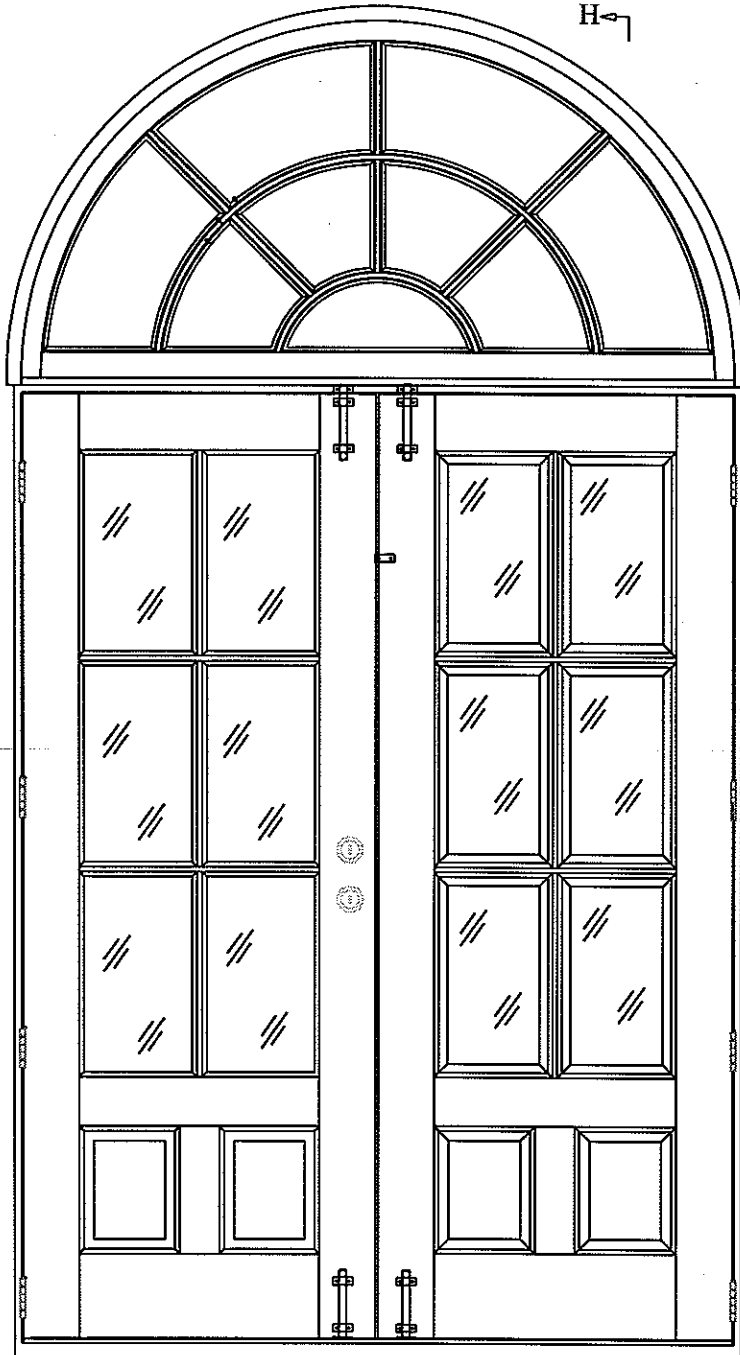

Section  
H-H

**Glass\*Craft**

Hardwood Double Glazed Doors/Transom



Test sample complies with these details.  
Deviations are noted.

Report# 81839.01-801-4  
Date 6/10/08 Tech Ⓢ

List of Material

Item #	Discription	Material
1	Masonry	CONC.
2	2x Buck	Wood
3	Astrical	Wood
4	Schlage lock Set	Metal
5	Rockwood Surface Bolts #580	Metal
6	Top Header	Wood
7	Penrond 4"x4" 5/8" Radius Hinge	Metal
8	Glass	Glass
9	Panel	Wood
10	Endura Sill ZAIL 5866 / I/S	Alum.
11	3" #9 Wood screw	Metal
12	#9x1" PFH Wood Screw	Metal
13	1/4 Round Trim	Wood
14	Mull	Wood
15	Stile	Wood
16	Door Jam	Wood
17	Bottom Door sweep	Rubber
18	10-32 Sex Bolt	Metal
19	Bottom Rail	Wood
20	weather strip	Foam
21	Endura Sill ZAIL 5866 / O/S	Alum.

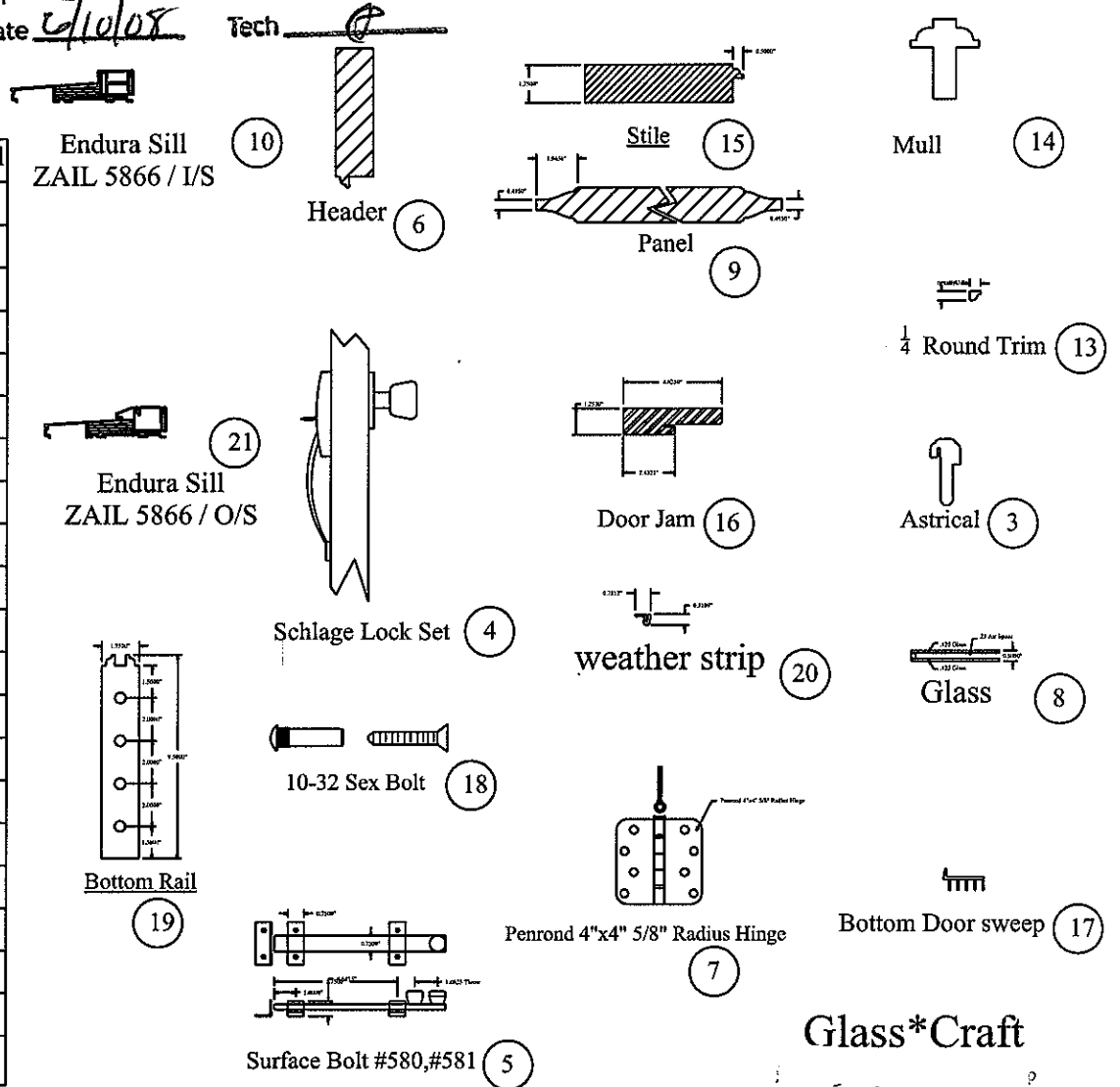



Architectural Testing

Test sample complies with these details.  
Deviations are noted.

Report# 81839.01 801-44  
Date 6/19/08 Tech [Signature]

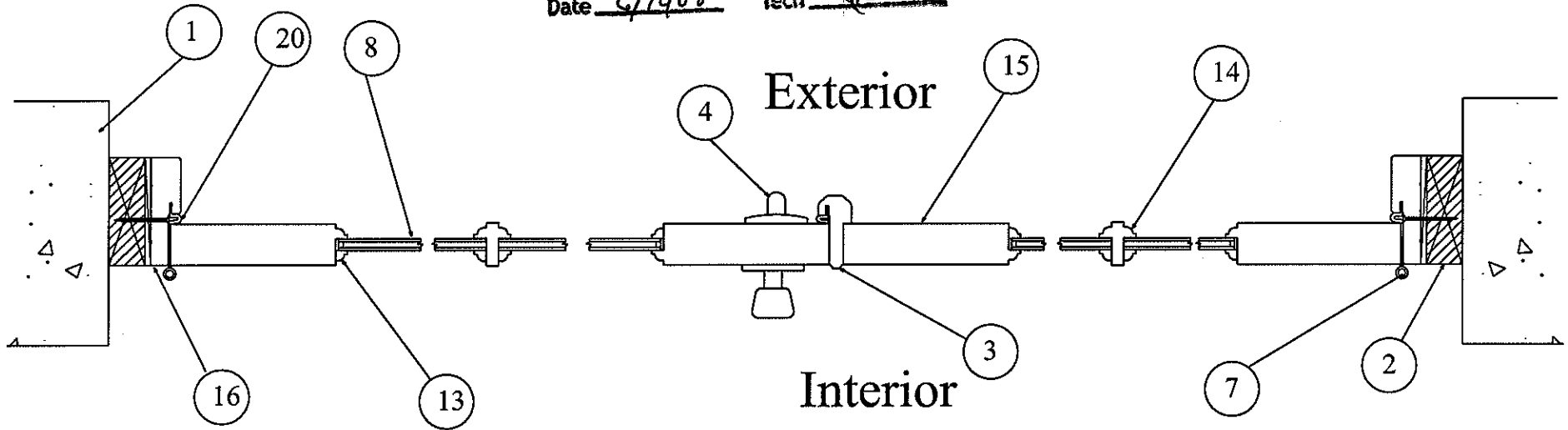

Horizontal Cross Section

Glass\*Craft

Hardwood Double Glazed Doors

*Carol Transom*

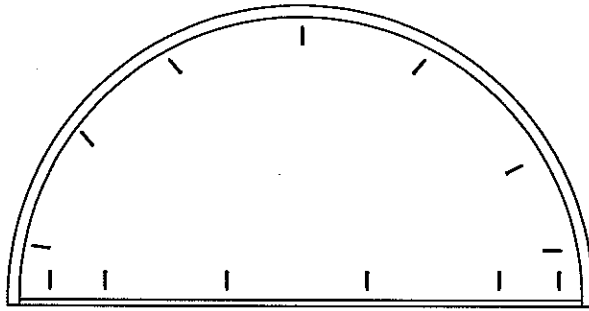

See Hinge Detail

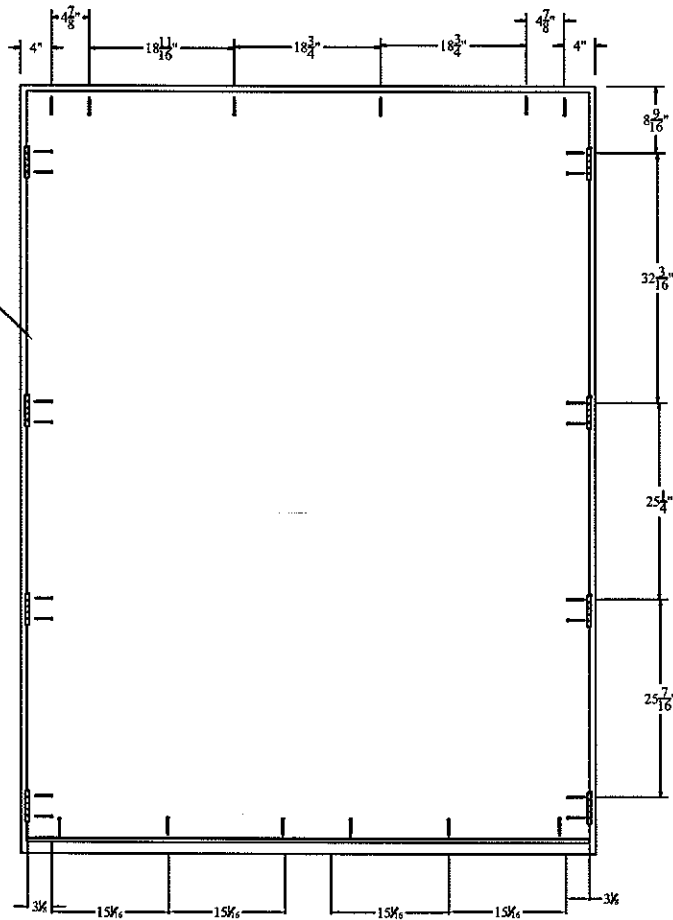

**Architectural Testing**

Test sample complies with these details.  
Deviations are noted.

Report# 81839.01-801-44  
Date 6/10/08 Tech R

## ANCHORING DIMENSION

# Glass\*Craft

Hardwood Double Glazed Doors/Transom

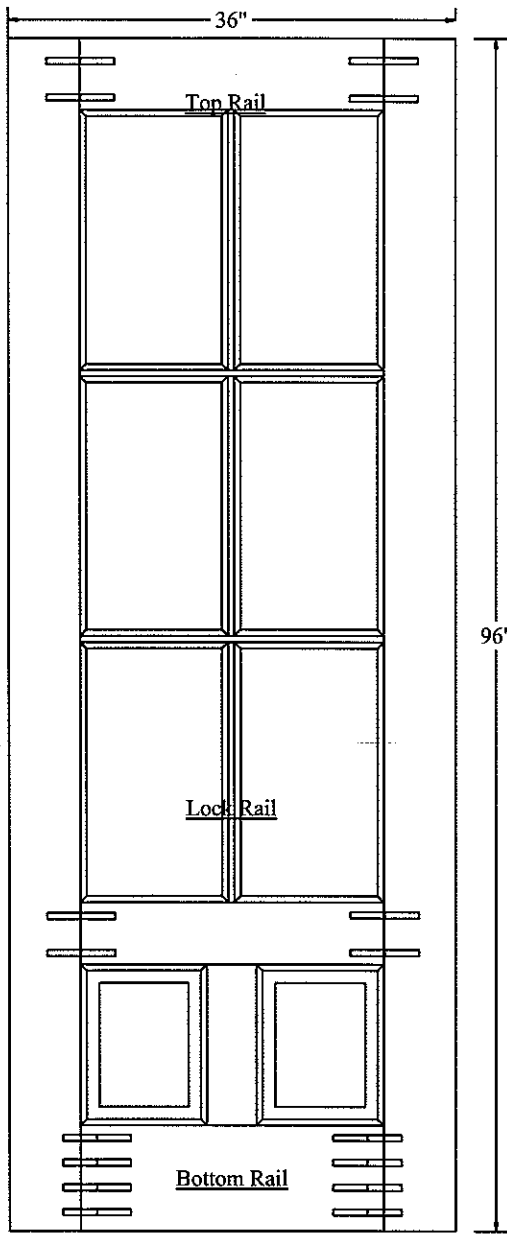

 **Architectural Testing**

Test sample complies with these details.  
Deviations are noted.

Report# 81839.01-801-44  
Date 6/10/08 Tech [Signature]

**Glass\*Craft**

Hardwood Double Glazed Doors/Transom



# Architectural Testing

Test sample complies with these details.  
Deviations are noted.

Report#

01839.01-801-44

Date *10/10/08*

Tech *R*

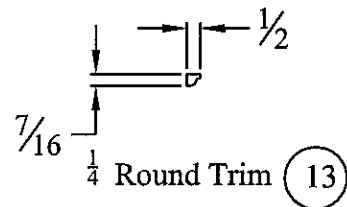
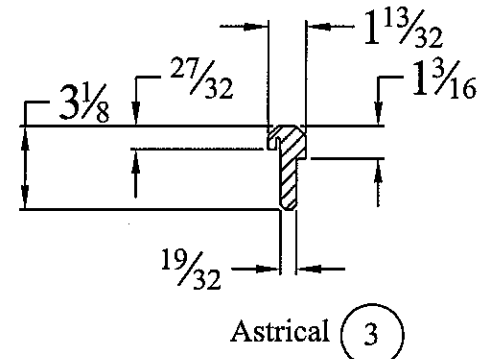
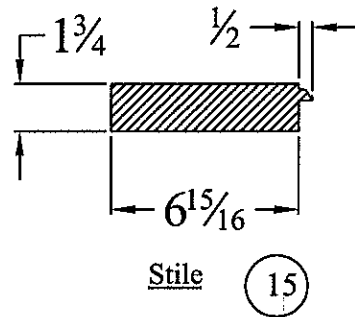
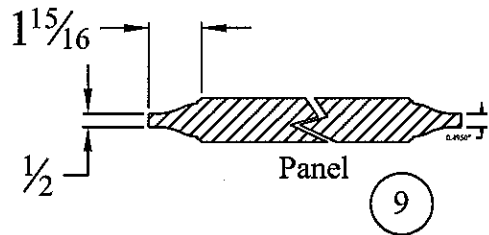
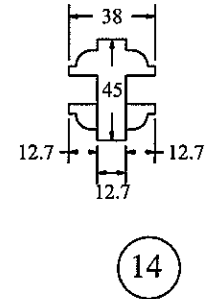
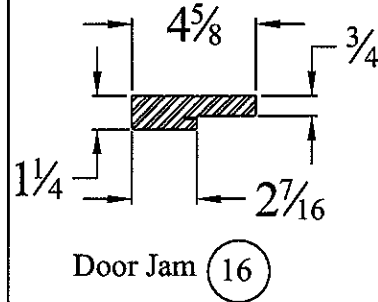
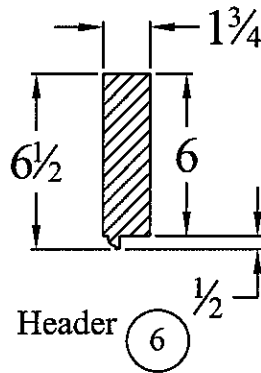
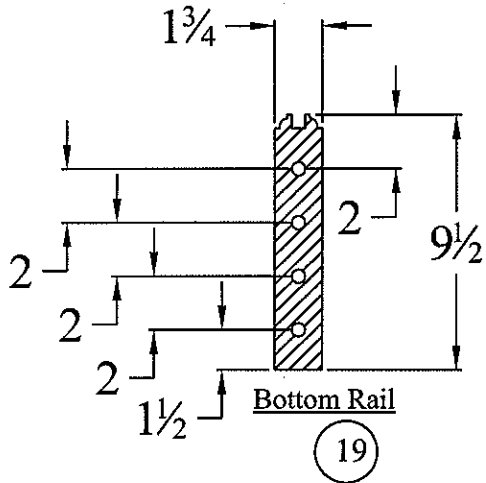

## Glass\*Craft

Hardwood Double Glazed Doors/Transom

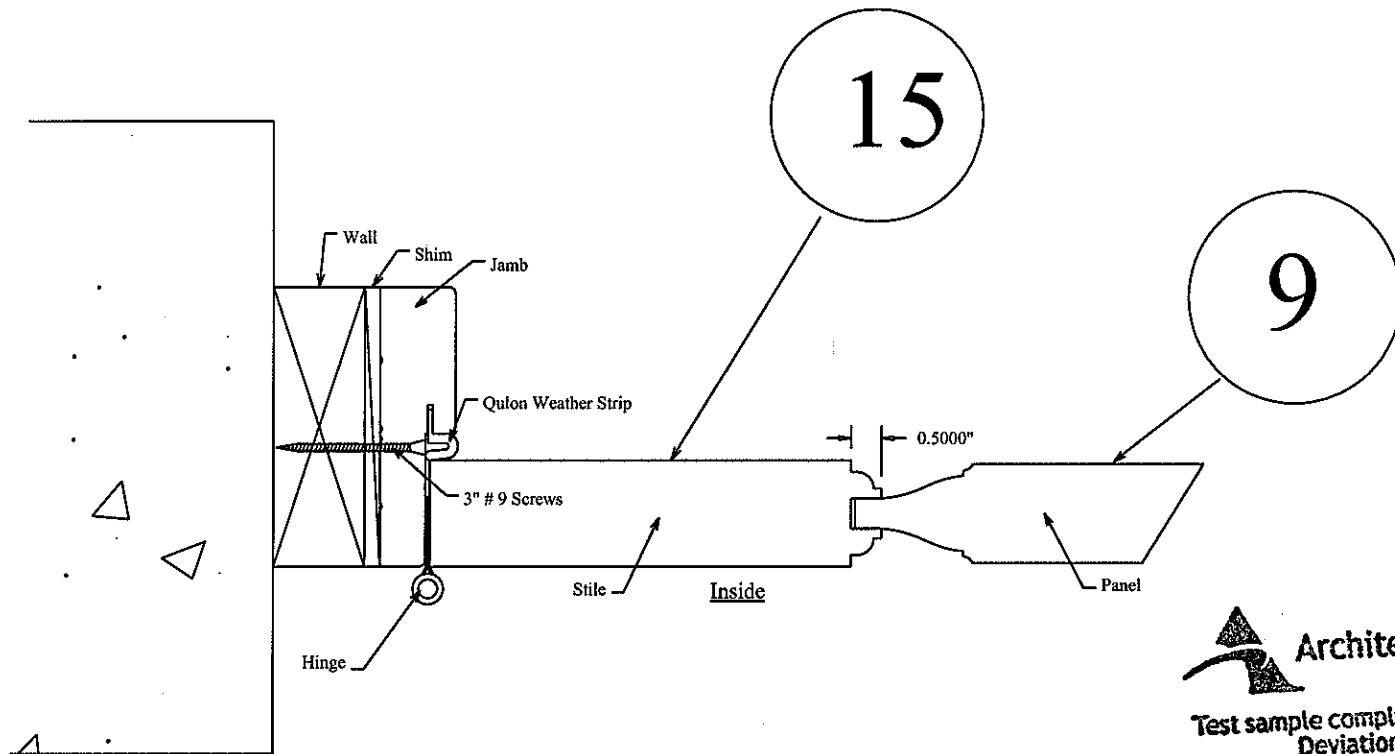

**Architectural Testing**  
 Test sample complies with these details.  
 Deviations are noted.  
 Report# 81839.01-801-84  
 Date 11/10/8 Tech. [Signature]

(B) \_\_\_\_\_ Panel

**Glass\*Craft**

Hardwood Double Glazed Doors/Transom



Test sample complies with these details.  
Deviations are noted.

Report# 81839.01-801-44  
Date 6/10/08 Tech PT

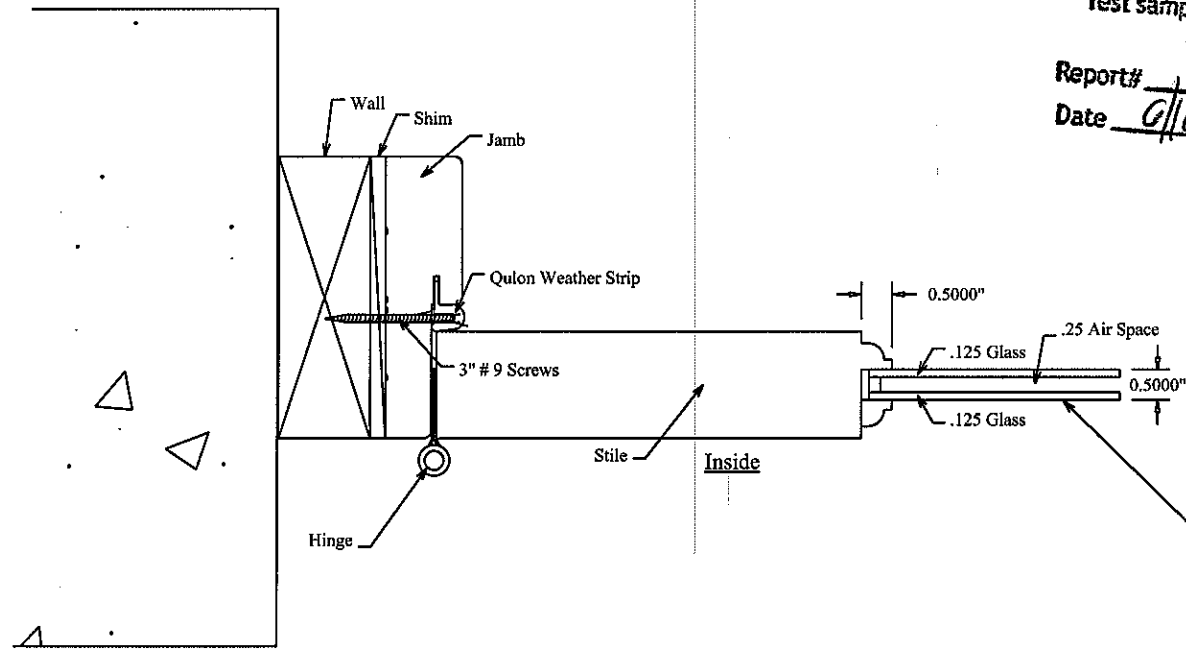

© Glass

Glass\*Craft

Hardwood Double Glazed Doors/Transom



# Architectural Testing

Test sample complies with these details.  
Deviations are noted.

Report# 81839-01-801-44

Date 6/10/08 Tech [Signature]

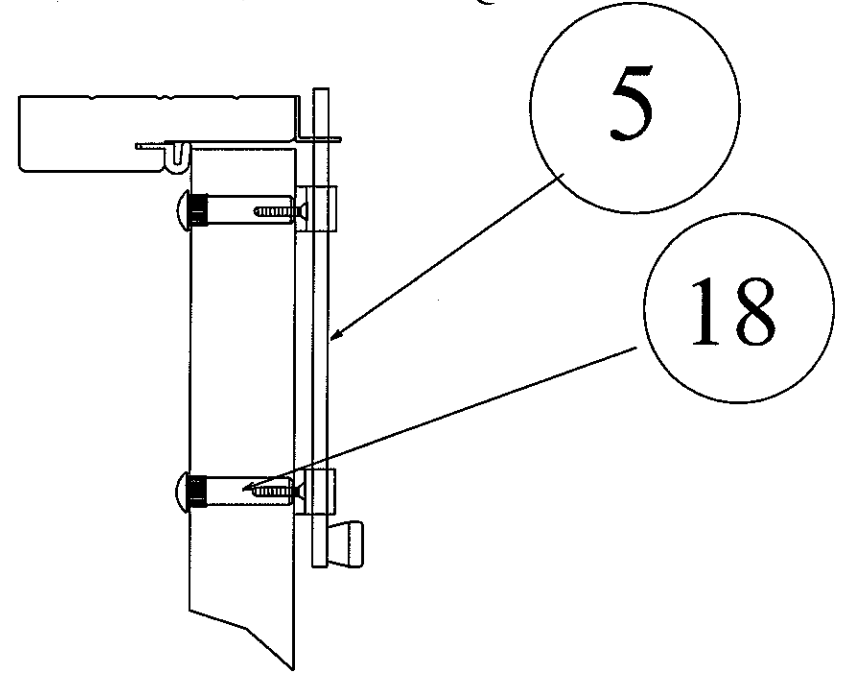
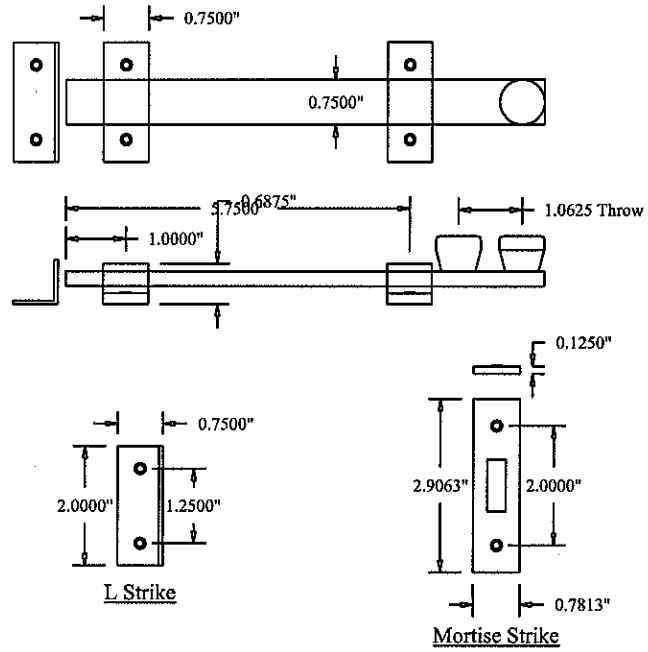

**(F)** Rockwood 580 Surface Bolt

## Glass\*Craft

Hardwood Double Glazed Doors/Transom

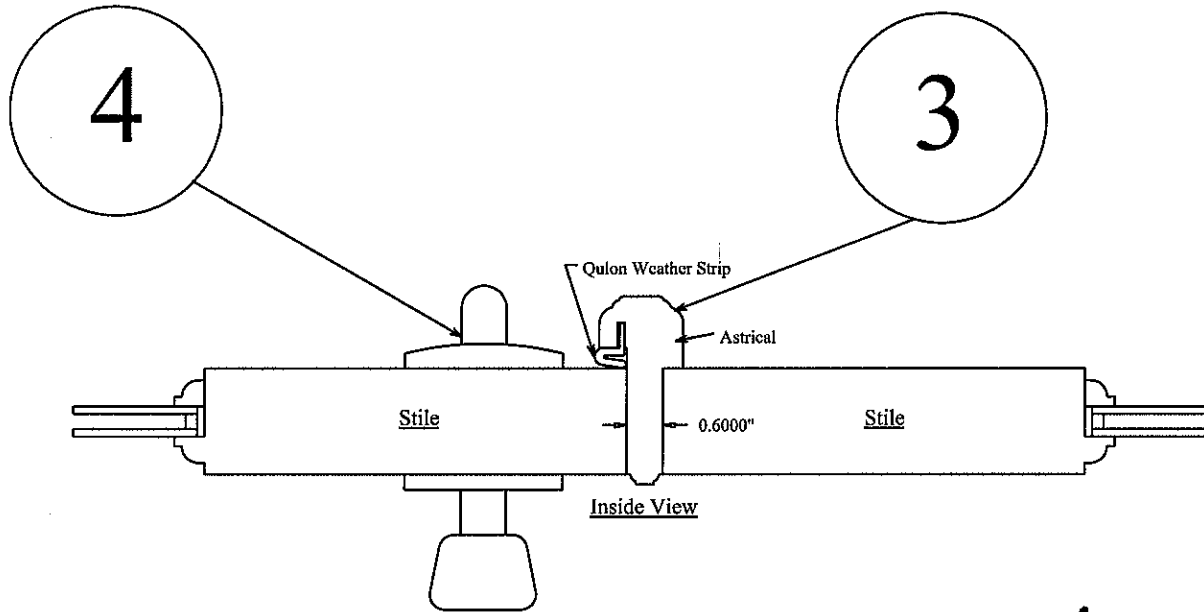

ⓐ Astrical

Endura Sill  
ZAIL 5866 / O/S

 Architectural Testing

Test sample complies with these details.  
Deviations are noted.

Report# 818301.01-801-44  
Date 6/10/08 Tech 

### Install Outside Housing

**NOTE:** Do not install adapter ring if using 1 3/8" (38 mm) hole.

- FOR F350/F352:** Ensure pin is positioned to slide through correct backset slot in deadbolt.
- Insert housing through escutcheon and adapter ring and into door. Driver bar should slide under deadbolt.

### Instalación del alojamiento exterior

**NOTA:** Si se usa un agujero de 38 mm no se instala un anillo adaptador.

- PARA LOS MODELOS F350/F352:** Se debe verificar que el pasador está colocado de manera que se deslice a través de la ranura en el pasador que corresponde a la distancia correcta del borde de la puerta al centro de la boquilla.
- Introducir el alojamiento en la puerta, a través del escudo y del anillo adaptador. La barra impulsora debe deslizarse debajo del pasador.

### Installation du logement extérieur

**REMARQUE:** Ne pas installer l'anneau adaptateur si le trou 38 mm est utilisé.

- POUR les modèles F350/F352:** S'assurer que la broche est placée de sorte à glisser dans la fente d'écartement correcte du pièce dormant.
- Insérer le logement par l'entree de serrure et l'anneau adaptateur si dans la porte. La barre d'entraînement doit glisser sous la pièce dormant.

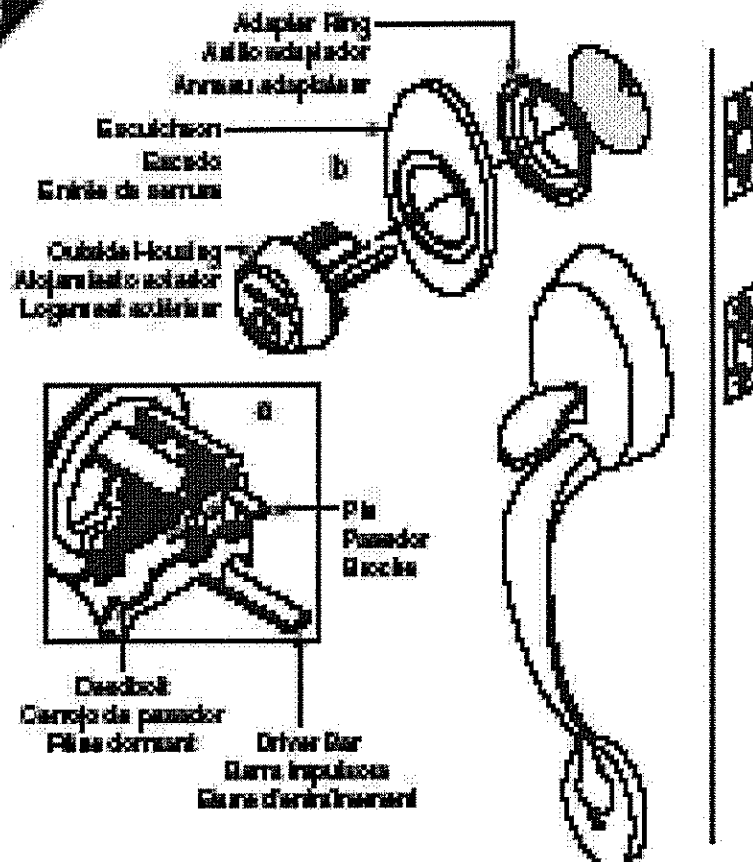

# Glass\*Craft

Hardwood Double Glazed Doors/Transom



Test sample complies with these details.  
Deviations are noted.

Report# 8183901-801-44  
Date 6/14/08 Tech AS



Architectural Testing

Test sample complies with these details.  
Deviations are noted.

Report# 81839.01-801-44

Date 6/10/08 Tech         

Beveled Safety Glass

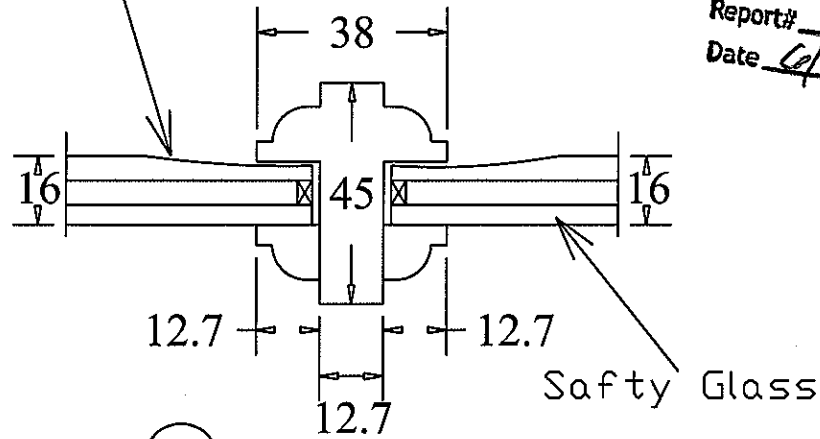

(C) CROSS SECTION

# Glass\*Craft

Hardwood Double Glazed Doors/Transom

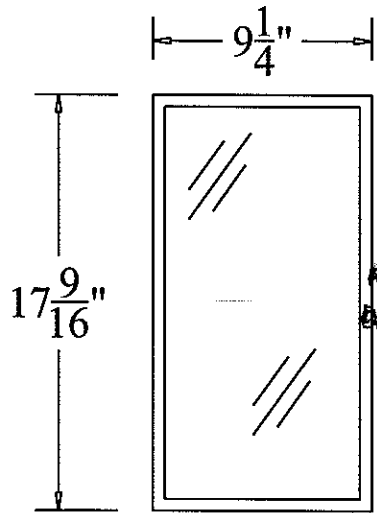

 **Architectural Testing**  
Test sample complies with these details.  
Deviations are noted.  
Report# 81839.01-801-44  
Date 6/1/08 Tech [Signature]

# Glass\*Craft

Hardwood Double Glazed Doors/Transom